

[CONTRIBUTION FROM THE CHEMICAL LABORATORY OF BROWN UNIVERSITY]

ALIPHATIC GERMANIUM DERIVATIVES.

I. TRIETHYLGERMANIUM COMPOUNDS; SOME OF THEIR PROPERTIES AND REACTIONS

BY CHARLES A. KRAUS AND E. ALISON FLOOD

RECEIVED NOVEMBER 24, 1931

PUBLISHED APRIL 6, 1932

I. Introduction

When three of the valences of the fourth group elements are satisfied by hydrogen or, more frequently, hydrocarbon radicals, they form groups of the type R_3A which in many respects resemble corresponding derivatives of carbon. In the case of tin, for example, the tertiary alkyl and aryl derivatives resemble the corresponding derivatives of triphenylmethyl in many respects. The corresponding silicon derivatives resemble triphenylmethyl less closely than do those of tin for the reason that the Si-Si linkage is much more stable than the Sn-Sn linkage, while the halogen derivatives of the type R_3SiX have a great tendency to hydrolyze.

The triphenylgermanium and the diphenylgermanium groups and some of their derivatives have previously been investigated¹ in this Laboratory. In the present paper are presented the results of a study of the triethylgermanium group and its derivatives. Since these derivatives have not heretofore been prepared, much of the present investigation is necessarily concerned with the preparation of compounds and the examination of some of their properties.

II. Triethylgermanium Halides and Di-triethylgermanium Oxide Tetraethylgermane

Preparation.—Triethylgermanium bromide, which serves as starting material in the preparation of triethylgermanium derivatives, may be prepared either by the partial ethylation of germanium tetrabromide by means of the Grignard reagent or by the substitution of one of the ethyl groups of tetraethylgermane by bromine. While we have found that triethylgermanium bromide may be prepared by the first method, the yields were not favorable. On the other hand, with suitable precautions, triethylgermanium bromide may be prepared from tetraethylgermanium by direct bromination with good yields.

Tetraethylgermanium was first prepared by Winkler,² using zinc ethyl as ethylating agent and more recently by Tabern, Orndorff and Dennis³ by means of the Grignard reagent. The latter authors report a yield of

¹ Kraus and Foster, *THIS JOURNAL*, **49**, 457 (1927); Kraus and Wooster, *ibid.*, **52**, 372 (1930); Kraus and Brown, *ibid.*, **52**, 3690, 4031 (1930).

² Winkler, *J. prakt. Chem.*, **144** (N. F. **36**), 177 (1887).

³ Tabern, Orndorff and Dennis, *THIS JOURNAL*, **47**, 2039 (1925).

60%. Using suitable precautions, we have found that tetraethylgermane may be prepared by the action of ethylmagnesium bromide on germanium tetrabromide with practically quantitative yield. In view of the high cost of germanium, we describe the method here.

A solution of 130 g. of germanium tetrabromide in ether was slowly added to a solution of ethylmagnesium bromide made up from 222 g. of ethyl bromide in 300 cc. of ether. During this process, the reaction mixture was strongly cooled and vigorously stirred by means of a motor-driven, mercury-sealed stirrer, an atmosphere of nitrogen being maintained over the reaction mixture. The mixture was boiled for two hours and allowed to stand overnight, when it was found to have separated into two layers. The ether was distilled from the mixture through a fractionating column, the mixture being stirred during the process. When most of the ether had been removed, a colorless solid separated from solution. At this juncture, care was taken to keep the mixture thoroughly stirred and uniformly heated. Finally, after removal of the uncombined ether, stirring was interrupted and the reaction mixture was heated to 110° for eight hours. The mixture was then cooled and ether was again added, the two liquid layers being reformed. The mixture was now chilled in an ice-bath, the excess Grignard reagent was destroyed and the product of reaction was extracted with ether. After drying, the ether, solution was distilled through a fractionating column. The higher boiling product was again distilled under reduced pressure. Three fractions were collected, a middle fraction of 56.7 g., boiling at 163.5° (uncorr.), and a higher and a lower boiling fraction of 3 g. each, which consisted chiefly of tetraethylgermane. Not counting these fractions, the yield was 91%.

The more common physical and chemical properties of germanium tetraethyl have been reported by Winkler, and more recently and completely by Dennis and Hance.⁴ Germanium tetraethyl is practically insoluble in liquid ammonia and perhaps for this reason does not react appreciably with a solution of sodium in liquid ammonia. It does not react with germanium tetrabromide to an appreciable extent at 100° although tin tetraethyl reacts readily with tin tetrachloride at room temperatures.⁵ The reaction of germanium tetraethyl with bromine is described in the next paragraph.

Triethylgermanium Bromide

Bromination of Germanium Tetraethyl.—Bromine reacts with germanium tetraethyl in solution in carbon tetrachloride, ethylene dibromide and ethyl bromide at higher temperatures. The rate of reaction and the purity of the product is greatly influenced by the nature of the solvent medium as well as by concentration. Ordinarily, a mixture of triethylgermanium bromide and higher bromides is obtained. We have found that, under suitable conditions, a high yield of relatively pure triethylgermanium bromide may be obtained by the action of bromine on tetraethylgermane in ethyl bromide.

Successive portions of a 50% solution of bromine in ethyl bromide were added to germanium tetraethyl during a period of six days, the mixture being maintained at a temperature of 40°. The total weight of bromine added was about 5% above that required for the replacement of one ethyl group. From 25 g. of germanium tetrabromide,

⁴ Dennis and Hance, *THIS JOURNAL*, **47**, 270 (1925).

⁵ Stafford, Thesis, Brown University, 1928; Kazeschkow, *Ber.*, **62**, 996 (1929).

26 g. of triethylgermanium bromide were obtained, boiling within a range of 2°, a yield of 82%.

The product could not be purified by repeated fractional distillations, but it was found possible to recrystallize the bromide from a petroleum ether solution at -50°. This method was employed in the initial preparations. Later it was found more advantageous to convert the bromide to the oxide, which is readily purified. The oxide was then reconverted to the desired halide. This method is described below.

Analytical Procedure.—Analyses for germanium were carried out by the method commonly employed in this Laboratory⁶ which consists in oxidizing the compounds by means of boiling, fuming sulfuric and nitric acids. The ethylgermanium derivatives are oxidized less readily than are the corresponding phenyl derivatives. As the nitric acid is boiled away, a point is reached where the solution takes on a greenish-brown color. If the process of boiling is continued at this point, a brown deposit is formed on the walls of the tube and germanium is lost, probably because of a volatile product present at this stage of the reaction. Accordingly, when this point is reached, a few drops of nitric acid are again added, boiling is resumed, and this process is repeated until, on continued boiling, a clear yellow solution results. The acids may then be fumed off and the tube and contents weighed after ignition.

Halogens, excepting fluorine, were determined as the silver halides. Since the triethylgermanium halides hydrolyze with some difficulty, a weighed sample was introduced into an ampule (2 cm. × 10 cm.) to which was then added a solution of potassium hydroxide. The neck of the ampule was then sealed, the mixture shaken vigorously and allowed to stand for twenty-four hours. The ampule was then opened and the organic material was extracted with petroleum ether. The residual alkaline solution was removed and the halogen precipitated by means of silver nitrate in the usual manner.

Anal. Subs., 0.5406, 0.4078: GeO₂, 0.2367, 0.1786. Calcd. for (C₂H₅)₃GeBr: Ge, 30.30. Found: Ge, 30.39, 30.41, mean, 30.40. Subs., 0.3836, 0.5175: AgBr, 0.3010, 0.4072. Calcd. for (C₂H₅)₃GeBr: Br, 33.35. Found: Br, 33.39, 33.48, mean, 33.43.

Properties.—Triethylgermanium bromide is a colorless, mobile liquid having an irritating, pungent odor resembling that of trimethyl tin bromide. It boils at 190.9°⁷ under a pressure of 760 mm. and freezes when cooled to -33°. It is soluble in ordinary organic solvents and in ethylamine. When triethylgermanium bromide is treated with water or, better, with alkaline aqueous solutions, it is hydrolyzed with the formation of diethylgermanium oxide. Hydrolysis, however, proceeds much less readily than it does with the corresponding compounds of silicon and it may be handled in air without appreciable change. In liquid ammonia, triethylgermanium bromide is appreciably ammonolyzed and by suitable means ammonolysis may be carried to completion, diethylgermaniumimine being formed.

Di-triethylgermanium Oxide

Preparation.—Impure triethylgermanium bromide is hydrolyzed with an aqueous solution of potassium hydroxide. The mixture is extracted with petroleum ether, the extract is dried with anhydrous sodium sulfate and then fractionally distilled. The chief impurity is diethylgermanium oxide which results on hydrolysis of diethylgermanium dibromide which is present as impurity. The latter oxide has a very high boiling point and thus is readily separated from triethylgermanium oxide. On the basis of a given sample of impure bromide, a yield of 97% was obtained.

⁶ Kraus and Brown, Ref. 1, 3693.

⁷ The boiling points of pure liquids as cited were determined by means of a calibrated thermocouple. All other temperatures are uncorrected.

Anal. Subs., 0.2765, 0.3550: GeO_2 , 0.1727, 0.2215. Calcd. for $[(\text{C}_2\text{H}_5)_3\text{Ge}]_2\text{O}$: Ge, 43.29. Found: Ge, 43.34, 43.31, mean, 43.32.

Mol. wt. (Cryoscopic method in benzene). Solvent, 17.94, 17.94, 15.55; solute, 0.3802, 0.9526, 0.6863; Δt , 0.325, 0.810, 0.686. Calcd. for $[(\text{C}_2\text{H}_5)_3\text{Ge}]_2\text{O}$: 335.4. Found: 326, 328, 324, mean, 326.

Properties.—Di-triethylgermanium oxide is a colorless liquid possessing a camphor-like odor, in which respect it resembles the corresponding silicon derivative. It boils at 253.9° under normal pressure and does not solidify at -50° . It is soluble in common organic solvents and in ethylamine, but is insoluble in water and in liquid ammonia. It is quite stable toward oxidation and may be heated to 250° in air without appreciable decomposition. When ignited, it burns readily with a smoky flame. Treated with concentrated aqueous solutions of the halogen acids, the oxide is converted to the corresponding triethylgermanium halide. The oxide reacts readily with lithium in ethylamine with the formation of a reddish colored solution and without evolution of gas. Presumably, reaction takes place according to the equation



On evaporating the amine, the lithium triethyl germanide ammonolyzes, triethylgermane being formed.

Triethylgermanium Iodide.—A quantity of di-triethylgermanium oxide was treated with hydriodic acid and allowed to stand overnight. The triethylgermanium iodide was then extracted with petroleum ether, the extract dried and fractionally distilled. The fraction collected at the practically constant temperature of 210° was finally redistilled *in vacuo*.

Anal. Subs., 0.5031, 0.4558: GeO_2 , 0.1843, 0.1669. Calcd. for $(\text{C}_2\text{H}_5)_3\text{GeI}$: Ge, 25.33. Found: Ge, 25.43, 25.41, mean, 25.42. Subs., 0.3843, 0.3749: AgI, 0.3141, 0.3065. Calcd. for $(\text{C}_2\text{H}_5)_3\text{GeI}$: I, 44.28. Found: I, 44.18, 44.19, mean, 44.18.

Properties.—Triethylgermanium iodide is a colorless, mobile liquid possessing a peculiar, garlic-like odor. It boils at 212.3° under normal pressure. In other respects it resembles the bromide.

Triethylgermanium Chloride.—The preparation is precisely similar to that of the iodide except that hydrochloric acid is used in place of hydriodic acid.

Anal. Subs., 0.3265, 0.3676: GeO_2 , 0.1755, 0.1981. Calcd. for $(\text{C}_2\text{H}_5)_3\text{GeCl}$: Ge, 37.20. Found: Ge, 37.31, 37.40, mean, 37.35. Subs., 0.1406, 0.1736: AgCl, 0.1038, 0.1281. Calcd. for $(\text{C}_2\text{H}_5)_3\text{GeCl}$: Cl, 18.17. Found: Cl, 18.26, 18.25, mean, 18.25.

Properties.—Triethylgermanium chloride is a colorless liquid boiling at 175.9° under normal pressure. It has a more penetrating odor than either the bromide or the iodide. In other respects it resembles the bromide although it appears to be somewhat less readily hydrolyzed.

Triethylgermanium Fluoride

Preparation.—The preparation of the fluoride resembles that of the other halides except that the reaction is carried out in a lead vessel. The oxide is treated with hydrofluoric acid in a lead cylinder which is closed at one end and provided with a stopper at the other. The petroleum ether extract is dried with anhydrous sodium sulfate, since calcium chloride reacts with the fluoride.

Since hydrogen fluoride acts upon glass, the analysis of the compound for germanium had to be modified. The fluoride was oxidized in the usual way, the resulting oxide was dissolved in dilute sodium hydroxide and the germanium was precipitated as sulfide from 6 *N* acid solution. The sulfide was thrown on a filter, washed and trans-

ferred to a weighed crucible by washing with ammonium hydroxide. After expelling the ammonia and oxidizing the sulfide, the oxide was calcined and weighed.

Anal. Subs., 0.1608, 0.2233: GeO_2 , 0.0940, 0.1308. Calcd. for $(\text{C}_2\text{H}_5)_3\text{GeF}$: Ge, 40.62. Found: Ge, 40.57, 40.65, mean, 40.61.

The fluorine was determined by two methods. The first was a modified Starcke method⁸ in which the fluorine was weighed as lead chlorofluoride, while the second consisted in hydrolyzing the fluoride with a solution of known alkalinity and titrating the excess alkali with a standard solution of hydrochloric acid. Neither method proved to be entirely satisfactory, although the latter gave the more satisfactory results.

Anal. Subs., 0.3652, 0.3764: PbClF ,⁹ 0.5461, 0.4699. Calcd. for $(\text{C}_2\text{H}_5)_3\text{GeF}$: F, 10.24. Found: F, 10.86, 10.99, mean, 10.92. Subs., 0.4036, 0.2732: cc. of 0.04727 N HCl, 46.33, 32.02. Calcd. for $(\text{C}_2\text{H}_5)_3\text{GeF}$: F, 10.24. Found: F, 10.31, 10.53, mean, 10.42.

Properties.—Triethylgermanium fluoride is a colorless liquid boiling at 149.0° under a pressure of 751 mm. It has an extremely penetrating odor. The fluoride is more stable toward hydrolysis than are the other halogen derivatives.

III. Reactions of Triethylgermanium Halides

With Ammonia.—The trimethyltin halides combine with one molecule of ammonia to form stable solids which are not ammonolyzed in liquid ammonia.¹⁰ On the other hand, triethyl silicon bromide is immediately and completely ammonolyzed in the presence of ammonia, either as vapor or liquid. As was to be expected, triethylgermanium bromide exhibits intermediate properties.

Ammino Triethylgermanium Bromide, $(\text{C}_2\text{H}_5)_3\text{GeBr}\cdot\text{NH}_3$.—On condensing ammonia on triethylgermanium bromide, which is a solid at liquid ammonia temperature, two liquid layers are formed, the upper layer occupying the greater volume. As the ammonia evaporates, both layers gradually disappear, a white solid being left behind. The reaction tube was maintained at -33° while the uncombined ammonia was removed by means of a pump. The tube was then weighed. The increase in the weight of the tube corresponds to the weight of combined ammonia. The following results were obtained: sample, 0.7409, 3.3991; NH_3 combined, 0.0477, 0.2505; moles of NH_3 per mole $(\text{C}_2\text{H}_5)_3\text{GeBr}$, 0.906, 1.035, mean, 0.970. The results indicate that one molecule of ammonia combines with one molecule of triethylgermanium bromide. Precise results are difficult to obtain because the vapor pressure of the compound (due to ammonia) is appreciable. If the tube is pumped too long, some ammonia is lost, while if it is not pumped sufficiently, some free ammonia is left behind. Since only one molecule of ammonia is involved in the reaction, the final product was not a mixture due to ammonolysis. The compound as above prepared was analyzed for bromine.

Anal. Subs., 0.1769, 0.2210: AgBr, 0.1327, 0.1668. Calcd. for $(\text{C}_2\text{H}_5)_3\text{GeBr}\cdot\text{NH}_3$: Br, 31.2. Found: Br, 31.9, 32.1, mean, 32.0.

At room temperatures, the solid has a vapor pressure of 10 mm. If the vapors are removed, a liquid is left behind, which is doubtless triethylgermanium bromide. On again adding ammonia, the solid is re-formed.

The formation of two liquid layers in the presence of liquid ammonia indicates that the compound is ammonolyzed. The lower and heavier layer comprises the germanium,

⁸ Starcke, *Z. anorg. Chem.*, **70**, 173 (1911).

⁹ On analysis of the chlorofluoride for chlorine, it was found to be contaminated with 4% of lead chloride.

¹⁰ Kraus and Greer, *THIS JOURNAL*, **45**, 3078 (1923).

as di-triethylgermaniumimine, while the upper layer contains the ammonium bromide. As the liquid ammonia is evaporated, interaction takes place between the two layers with the re-formation of the ammoniated triethylgermanium bromide.

Reaction with Sodium in Liquid Ammonia.—If triethylgermanium bromide is ammonolyzed in the presence of liquid ammonia as suggested above, then, on addition of an alkali metal, reaction should take place with the evolution of hydrogen. On the other hand, if no ammonolysis occurs, the bromide should be reduced to the free triethylgermanium group, which would form the dimer, hexaethyldigermane.

On adding sodium to a solution of triethylgermanium bromide in liquid ammonia a vigorous reaction occurs with evolution of hydrogen. During this reaction, the lower layer in the reaction tube remains practically unchanged.

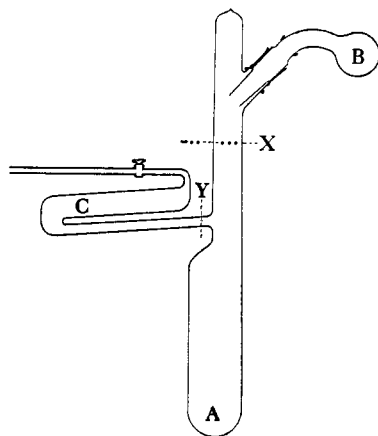

Fig. 1.—Apparatus used in preparing di-triethylgermaniumimine.

Di-triethylgermaniumimine.—In order to establish the nature of the lower liquid phase which contains the germanium residue after ammonolysis, a reaction was carried out in an apparatus of the form sketched in Fig. 1. Triethylgermanium bromide was introduced into the reaction chamber A, 15 cc. of liquid ammonia was condensed on the sample and sodium was added from the addition tube B. When the reaction appeared to be complete, the ammonia was allowed to evaporate and the reaction tube was sealed off at X. The tube was then turned through an angle of 90° and the high boiling liquid was distilled into C under reduced pressure. From the collecting tube C the liquid was distilled into a second tube in which the compound was filled into weighed fragile bulbs under nitrogen. These weighed samples were analyzed for germanium and nitrogen. The germanium was determined in the usual way.

Nitrogen, in one analysis, was determined by the Kjeldahl method, and in another by breaking the fragile bulb, containing the sample, under ice cooled water and titrating the resulting aqueous solution with hydrochloric acid.

Anal. Subs., 0.1340, 0.2500: GeO_2 , 0.0838, 0.1564. Calcd. for $[(\text{C}_2\text{H}_5)_3\text{Ge}]_2\text{NH}$: Ge, 43.41. Found: Ge, 43.40, 43.42, mean, 43.41. Subs., 0.4473, 0.4714, cc. of 0.04727 *N* HCl, 27.91, 29.25. Calcd. for $[(\text{C}_2\text{H}_5)_3\text{Ge}]_2\text{NH}$: N, 4.19. Found: N, 4.13, 4.11, mean, 4.12.

Di-triethylgermaniumimine is a colorless, mobile liquid which is insoluble in liquid ammonia. It distils at a temperature of approximately 100° under a pressure of 0.1 mm. It reacts vigorously with water to form di-triethylgermanium oxide.

Reactions with Lithium in Ethylamine.—Compounds of the type R_3AX , if they do not ammonolyze, may be reduced by means of the alkali metals in liquid ammonia with the formation of the free group which is usually obtained as a dimer. Since triethylgermanium halides are appreciably ammonolyzed in liquid ammonia, their reduction cannot be carried out in this solvent. It was thought, however, that such reduction might be effected in ethylamine, which is a weaker ammonolyzing agent. Both the bromide and the chloride react with lithium in ethylamine with the evolution of more or less hydrogen, depending upon conditions. The fluoride has less tendency to ammonolyze than do the other halides. By breaking a bulb containing the fluoride under a solution of lithium in ethylamine, reaction occurs without the evolution of hydrogen.

From the product of this reaction was obtained a high-boiling liquid which was doubtless hexaethyldigermene. Reduction takes place according to the equation

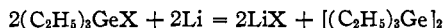

The reaction is probably complicated owing to the formation of lithium triethyl germanide. As a method for the preparation of the digermene, the reduction of the halides in ethylamine is unsatisfactory.

IV. Hexaethyl Digermene

Preparation.—While triethylgermanium bromide does not react with sodium in boiling xylene, it may be conveniently reduced by the direct action of sodium on pure triethylgermanium bromide at elevated temperatures.

Twenty-five grams of triethylgermanium bromide and 10 g. of sodium were introduced into a flask which was provided with a long neck that served as an air condenser. Near the top of the condenser, the flask was connected to a mercury manometer. After introducing the reaction materials, the flask was sealed. The reaction mixture was heated on a Wood's metal bath until the sodium melted, when the metal was broken up into small droplets by shaking the tube. The temperature of the bath was then slowly raised to 210°, where the triethylgermanium bromide began to boil. The bath was maintained at this temperature for about twelve hours, during which time the pressure in the tube remained practically constant at 760 mm. The temperature of the bath was then gradually raised over a period of five days to 270°, the pressure in the manometer being raised, in the meantime, to 1200 mm, by means of a suitable leveling bulb. The pressure and temperature were always so adjusted that the level of the vapor did not rise too high in the condensing column.

At the end of the reduction process, the reaction mixture consisted of a dark blue, solid mass. The product was extracted with petroleum ether and the extract was fractionally distilled through an Eastman column.

The fraction collected between 250 and 270° was treated with strong hydrochloric acid in order to convert any ditriethyl germanium oxide to the lower boiling chloride. The resulting mixture was extracted with petroleum ether, the extract was dried and fractionally distilled. The product was concentrated by repeated fractional distillations until about 10 g. of halogen-free liquid were obtained which boiled at the practically constant temperature of 265°.

Anal. Subs., 0.2637, 0.3385: GeO_2 , 0.1730, 0.2215. Calcd. for $[(\text{C}_2\text{H}_5)_2\text{Ge}]_2$: Ge, 45.45. Found: Ge, 45.53, 45.42, mean, 45.47.

Mol. wt. (Cryoscopic method in benzene). Solvent, 12.57, 17.03; solute, 0.8798, 0.9342; Δt , 1.068, 0.857. Calcd. for $[(\text{C}_2\text{H}_5)_2\text{Ge}]_2$: 320. Found: 328, 320, mean, 324.

Properties.—Hexaethyldigermene is a colorless, mobile liquid of a rather pleasant odor. It boils at 265.0° under a pressure of 758 mm. and fails to solidify at -60°. It is soluble in ordinary organic solvents and in ethylamine but is insoluble in water and in liquid ammonia. Hexaethyldigermene is relatively stable toward oxygen since it may be distilled in air without noticeable change.

Reaction of Hexaethyldigermene with Bromine.—Hexaethyldigermene reacts readily and quantitatively with bromine to form triethylgermanium bromide. On treating the digermene with a solution of bromine in ethyl bromide, vigorous reaction occurred. On cooling to ice temperature, reaction proceeded quietly, the color disappearing almost immediately. After removing the ethyl bromide, the residual liquid was found to boil at 188° under atmospheric pressure. The boiling point of triethyl-

germanium bromide is 191°. The Ge-Ge bond is evidently broken rather readily by bromine.

Reaction with Lithium in Ethylamine.—Hexaethyldigermene does not react appreciably with sodium in liquid ammonia. This is in part due to the low solubility of the digermene. On adding ether to the liquid ammonia solution, appreciable reaction occurs, but it is too slow for purposes of preparation.

Lithium reacts rather readily with a solution of hexaethyldigermene in ethylamine. The reaction proceeds without the evolution of gas, which indicates that a lithium salt is formed. The solution, on completion of the reaction, has a somewhat brownish color. When the ethylamine was evaporated, on completion of the reaction, and the tube was weighed, it was found that germanium had been lost. When ammonia was condensed on the residue, after evaporation of the ethylamine, a small quantity of insoluble liquid appeared. Ammonium bromide was added to the liquid ammonia solution without noticeable effect. On evaporating the liquid ammonia and recondensing it, droplets of liquid were collected, which indicated the presence of a volatile compound carried over by the ammonia vapor.

These results indicate that lithium reacts with hexaethyldigermene to form lithium triethylgermanide according to the equation

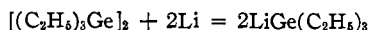

In ethylamine and, more completely, in ammonia, the lithium salt ammonolyzes according to the equation

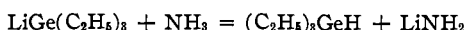

triethylgermane being formed.

Triethylgermane.—The above reaction suggests a method for the preparation of triethylgermane. A solution of 2.05 g. of hexaethyldigermene in 10 cc. of ethylamine was treated with 0.09 g. of lithium. When the reaction appeared to be complete, the ethylamine was distilled through an ice cooled trap into a suitable receiver. A small quantity of liquid (triethylgermane) condensed in the trap. The bath was removed from the trap and ammonia was passed through the trap and condensed in the reaction tube. The liquid in the trap disappeared in the course of this process. Two liquid layers were formed in the reaction tube, the lower of which was colorless and the upper of which was colored blue owing to the presence of some excess lithium. Ammonium bromide was added to the reaction mixture until the color was dispelled. Triethylgermane was present in the bottom of the reaction tube as a colorless liquid. In order to separate the volatile triethylgermane from the supernatant ammonia, the latter was withdrawn through a suitable tube which was lowered until it almost reached the surface of the liquid. The product was repeatedly washed with fresh ammonia in this way. After washing, the product was twice distilled *in vacuo*, the vapors being passed over phosphorus pentoxide in the final distillation in order to remove traces of ammonia.

The molecular weight of the final product was determined by the vapor density method, a suitable calibrated tube being used for this purpose.

Mol. wt. (Vap.). Subs., 0.03115, 0.03150; vol., 301.3, 301.3; pressure, mm., 12.1, 12.0; *t*, 27.0, 26.1. Calcd. for $(C_2H_5)_3GeH$: 160.7. Found: 161.1, 162.6, mean, 161.8.

Anal. Subs., 0.2097, 0.1923; GeO_2 , 0.1365, 0.1250. Calcd. for $(C_2H_5)_3GeH$: Ge, 45.17. Found: Ge, 45.18, 45.12, mean, 45.15.

Properties.—Triethylgermane is a colorless, mobile liquid having a camphor-like odor. It boils at 124.4° under a pressure of 751 mm. It is soluble in organic solvents and insoluble in water and liquid ammonia. It readily decolorizes a solution of bromine in ethyl bromide. It does not appear to react with a solution of sodium in liquid ammonia.

It reacts readily with a solution of potassium amide in liquid ammonia with the evolution of a gas, presumably hydrogen. Potassium triethyl germanide, therefore, cannot be prepared by the action of potassium amide on triethylgermane.

Reaction of Hexaethyldigermane with Potassium in Ethylamine.—The preceding experiments indicate that lithium triethyl germanide is largely ammonolyzed in ethylamine and completely so in ammonia. Since potassium amide is a much stronger base than lithium amide, it was thought that potassium triethyl germanide might be stable in liquid ammonia solution.

The salt was prepared by the direct action of metallic potassium on a solution of hexaethyldigermane in ethylamine. 0.37 g. of the digermane was introduced into leg B of the reaction tube shown in Fig. 2 and 0.089 g. of potassium was introduced into leg A. Liquid ammonia was condensed upon the metal and the solution was evaporated rapidly so as to distribute the potassium as a thin film over the inner wall of leg A, thus exposing a large surface. After exhausting the tube, ethylamine was condensed in leg A. Tubes F and E were then sealed and ethylamine was decanted into leg B and returned to leg A, the process being repeated until all the digermane had been washed into leg A. The tube was then left for a period of six weeks, at the end of which time the metal had disappeared completely and a clear yellow solution was present in leg A. The reaction tube was now attached to the system and the stopcock D was turned, breaking the end of the capillary H. The ethylamine was distilled from the solution in A and, after exhausting thoroughly, ammonia was condensed on the solid material that remained behind. There was no evidence of ammonolysis, a clear yellow solution being formed. Presumably, this was a solution of potassium triethyl germanide in liquid ammonia.

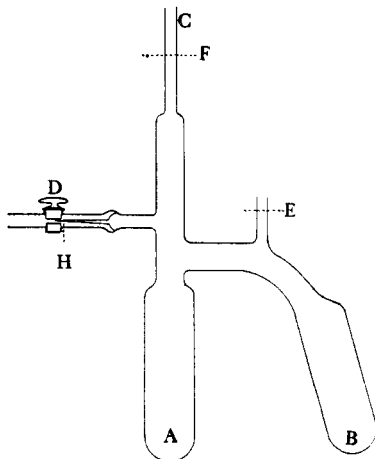
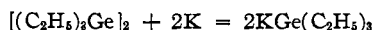

Fig. 2.—Apparatus for preparing potassium triethyl germanide.

To definitely establish this fact, the tube F was cut and ethyl bromide was added until the color of the solution in A was completely discharged. As the reaction proceeded, an insoluble liquid separated from solution and settled to the bottom. The ammonia was now evaporated, the residual liquid extracted with petroleum ether and, after drying, the petroleum ether was removed by distillation. The remaining liquid was distilled and collected in two fractions. Nearly all the liquid was collected in the first fraction, which boiled at 162–164°, identifying it as germanium tetraethyl (b. p. 163.8°). The other fraction had a very high boiling point, and probably was hexaethyldigermane, a slight excess of which was used in the original preparation.

Potassium triethylgermanide was evidently formed in ethylamine according to the equation



On addition of ethyl bromide to the ammonia solution of the potassium salt, reaction took place as follows

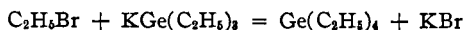

Potassium triethyl germanide may evidently be prepared as above described in practically quantitative yield.

Summary

A convenient method is described for the preparation of tetraethylgermane which gives excellent yields.

The preparation of the triethylgermanium halides and of di-triethylgermanium oxide is described and some of their more common properties are recorded.

The reaction of the triethylgermanium halides with ammonia and with solutions of the alkali metals in ammonia and ethylamine have been studied. The preparation of di-triethylgermanyylimine is described.

The preparation of hexaethyldigermane is described. The reaction of this digermane with the alkali metals in ammonia and ethylamine has been studied. The preparation of triethylgermane is described as are also some of its reactions.

A method is described for the preparation of potassium triethylgermanide.

PROVIDENCE, RHODE ISLAND

[CONTRIBUTION FROM THE CHEMICAL LABORATORY OF THE FRIEDRICH WILHELM UNIVERSITY IN BERLIN]

THE REACTION BETWEEN KETOXIDO COMPOUNDS AND GRIGNARD REAGENTS

BY ERNST BERGMANN AND H. A. WOLFF

RECEIVED NOVEMBER 30, 1931

PUBLISHED APRIL 6, 1932

In a recent communication¹ Kohler and co-workers describe experiments on the reaction of ketoxido compounds with Grignard reagents. Benzalacetophenone oxide, for instance, is transformed into triphenylcarbinol by phenylmagnesium bromide

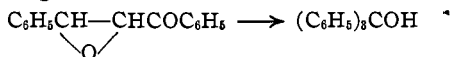

and Kohler assumes on the basis of many experiments that in the first step of the reaction the benzoyl group is split off as benzophenone, which is then transformed into the carbinol.

The same reaction has been studied in our laboratory during the past year, some of Kohler's experiments have been carried out also by us and we wish to report some evidence confirming his results.

Although in most cases Grignard reagents react with ketoxido compounds in the same way as with benzalacetophenone oxide, benzal-*p*-phenylacetophenone oxide (I) is not converted into a triarylcarbinol by phenylmagnesium bromide; instead, two different products are isolated. One of these is the pinacol of phenyl biphenyl ketone (II). Its formation can hardly be understood unless we assume, as does Kohler, that in the pri-

¹ Kohler, Richtmyer and Hester, *THIS JOURNAL*, 53, 205 (1931).